



Intelligent Pump Drive

200-240V Single Phase: 1 to 5 HP

200-240V Three Phase: 3/4 to 175 HP

380-480V Three Phase: 1 to 1000 HP

500-600V Three Phase: 2 to 250 HP



iQPUMP[®]



iQpump Family

Yaskawa's family of iQpump® drives offers a wide variety of package options and the most advanced comprehensive pump and motor protection in the industry, while still maintaining ease of setup and diagnostics designed for pump operators and service technicians. Our integrated pump specific software allows for a wide range of pumping applications from constant pressure, flow, geothermal, multiple pump booster systems to wet well lift stations and many others. As process variables change, iQpump automatically adjusts pump operating conditions to meet system demand, while maintaining pump performance and protection. Our goal is to ensure that the pump is operating at the best efficiency point (BEP) on the curve so that the system produces only what is required, saving energy and decreasing life cycle costs.

When your pump control needs are wide ranging from pressure, flow, level, pump down, geothermal, enhanced I/O and network communications, Yaskawa's iQpump1000 offers one simple comprehensive drive and software package. iQpump1000 is your total pumping solution for whatever your system demands, while maintaining the simple pump terminology programming customers have come to expect.

Yaskawa understands that many light commercial, industrial, agricultural and ground water well systems are looking for a more cost effective simplex and multiplex constant pressure pump control solution without sacrificing what they have come to enjoy from Yaskawa. iQpump Micro offers many of the same comprehensive software features and control along with the same programming interface as iQpump1000, but in a package that saves cost. iQpump Micro is available in NEMA 1, NEMA-4X and NEMA 3R.



iQpump1000

NEMA 1, NEMA 12, & NEMA 3R:

1-175HP, 3-Phase Input, 240V Class
1-1000HP, 3-Phase Input, 480V Class
2-250HP, 3-Phase Input, 600V Class



iQpump Micro

NEMA-4X:

1-3HP, 200-240V, 1-Phase Input
1-25HP, 200-240V, 3-Phase Input
1-25HP, 380-480V, 3-Phase Input

NEMA 1 & 3R:

1-5HP 200-230V 1-Phase Input
1-25HP 200-240V 3-Phase Input
1-25HP 380-480V 3-Phase Input

Note: iQpump Micro comes standard with a 7 segment LED panel operator. Therefore, when commissioning, changing parameters or troubleshooting, it is recommended that the remote Hand-Off-Auto (H-O-A) operator be utilized for plain English. This operator can be mounted remotely to any enclosure door.



System Benefits

Improved Process Control and System Reliability

By matching pump output flow or pressure directly to the process requirements, applications can be fine tuned more rapidly by iQpump than by other control forms. Any reduction in speed achieved by using iQpump has major benefits in reducing pump wear, particularly in bearings and seals.

Reduce Total System Cost

iQpump lowers system cost by eliminating sensors, jockey pumps, and restriction valves, as well as reducing pressure tank sizing.

Energy Savings

Depending on the application, iQpump reduces the demand for energy by 20 to 50% by adjusting pump speed to match a lower flow/pressure.

Ease of Installation and Set Up

iQpump uses pump terminology on all setup parameters and monitors. Application presets apply most of the parameters for you. Also included is a “Pump Quick Setup” and “Modified Constants” menu.

Eliminate Complex Control Panels

By installing iQpump, many electromechanical controls can be eliminated. This reduces the maintenance these panels require.

Reduce Mechanical Stress and Damage to Pumps

iQpump has soft-start and soft-stop capabilities, eliminating pressure surges and water hammer.

Cooler Running Pump Motor

Soft starts eliminate high inrush current, dramatically increasing winding insulation life.

Utility Harmonics Estimator

Estimation of harmonics contribution back to main power source.

Energy Savings Predictor

Analysis of energy savings with carbon footprint calculation.

Application Simulator Software

Software allows for the user to program multiple pump applications and then simulate operation without the need for a drive.

Energy Savings Example

Energy consumption follows the affinity laws, which means flow is proportional to speed, pressure is proportional to the square of speed, and horsepower is proportional to the cube of speed.

Example: Application

- Required 80 percent flow
- Pump runs at 80 percent of rated speed
- Motor requires 50 percent of rated power

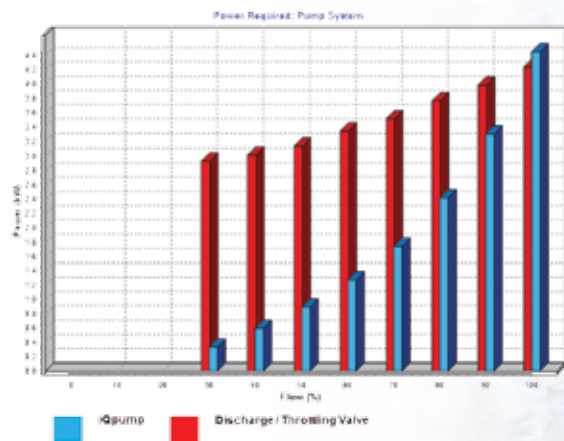

Result: Reducing speed by 20 percent requires only 50 percent of the power.

PC SCADA

Troubleshooting, Monitoring, Startup Wizard, Programming, and Trending.



Designed with Pump Operators in Mind

Designed with the user in mind, iQpump uses intuitive pump related terminology, with simple process control selection of engineering units such as PSI, GPM, feet, metric, temperature, inches of mercury, and many other process control units.

Pump Specific Hand-Off-Auto (HOA) Operator



System Pressure Setpoint

Control Operation Status: Drive being controlled via keypad operation or by external run command.

Pump Motor Output Frequency

Transducer Feedback

Drive Status Monitors: By using F1 & F2, a user can quickly scroll through drive running statuses, such as, motor amps, motor speed, power consumed, etc.

Real Time Clock

iQpump is supported with a real time clock that will log the last 10 fault events with a date and time stamp to provide the pump service technicians with real data for troubleshooting. This feature also enables the user to set calendar run and stop configurations, allowing the system to avoid high utility kW rates during peak operation hours.

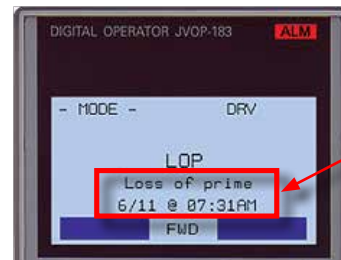

Date & Time Stamp

H-O-A Operator Keypad

What makes iQpump the industry standard is the simplicity of the operator keypad messages that are formatted in pump terminology. This informs the user about the status of the system operation along with alarms or specific pump algorithm functions that are being initiated.

Pre-Programmed Application Macros

Pre-programmed application presets reduce start-up time significantly. Users enter simple motor and application information within the pump quick setup menu for each of the application macros.



APPLICATION MACROS:

- ▶ Constant Pressure
- ▶ Pump Down Level Control
- ▶ General Purpose Mode
- ▶ Submersible Motor, General Purpose, Operator Control
- ▶ * Geothermal Control
- ▶ * Vertical Turbine Pump Pressure Control (VTC)

* Not Supported with iQpump Micro

Protection

Pump Fault and Alarms

iQpump provides a comprehensive set of pump related alarms and faults. Faults are displayed on the keypad in clear text to eliminate confusion (the following is just a sample):

- Over Cycling
- Transducer Feedback Lost
- Set Point Not Met (Broken Pipe Detection)
- No Flow
- Over Torque
- Low and High Feedback Detection
- Pumping Over Cycle Protection
- Loss of Prime/Dry Run
- Pump Cavitation Protection

iQpump Drive Protection

- Over / Under Voltage
- Short Circuit
- Input Phase Loss
- Over Temperature
- Phase Imbalance
- Heatsink Fan Failure

Motor Protection

- Output Phase Loss
- Motor Over Temperature
- Hard Current Limit
- Ground Fault
- Broken Shaft
- Motor Overload
- Minimum Speed

Why use Single-Phase

UL Tested and Approved for use on Single-Phase Power

In rural areas or commercial office buildings that were not originally designed to support heavy manufacturing, utilities do not install three-phase power because the cost is significantly more than single-phase power. For many years, people have been using different technology to generate three-phase power from single-phase power sources. Common technologies include rotary-phase converters, static-phase converters, and variable frequency drives. As initial investment costs of variable frequency drives have dropped, more users are turning to iQpump as the best solution to convert single-phase pump motor applications to three-phase.

Benefits of Three-Phase over Single-Phase Motors

1. Three-phase motors are more compact and less costly than a single-phase motor of the same voltage class and HP (kW) rating.
2. Single-phase AC motors above 10 HP (7.5 kW) are not as efficient and are not usually manufactured in large quantity.
3. Three-phase motors have better starting torque, run more efficiently (i.e. 90% compared to 70%), and last much longer than their single-phase counterparts.
4. iQpump provides motor protection while increasing efficiency and reducing system cost.
5. Reduced motor cable sizes equal lower cost for long motor runs.

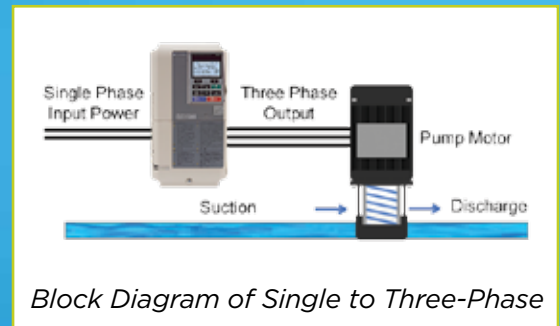

Note: When sizing iQpump for single to three-phase power conversion, consult your local Yaskawa Representative.

Environmental Considerations

Yaskawa maintains a corporate commitment to sustainability goals with an emphasis on the following environmental guidelines

RoHS

Restriction of Hazardous Substances



Leadership in Energy and Environmental Design



EPA program to promote superior energy efficiency



Energy Efficiency with Reduction of Carbon Footprint

Merging Green and Technology

Yaskawa Advantages

Technical Training

Both standard and customized courses are available with hands-on activities and demonstrations. Instruction is offered at Yaskawa locations as well as traveling road shows, and is supplemented by live web classes and e-Learning modules / videos to provide the right level of training to fit your needs. Trainers are degreed engineers with extensive industry experience.



Traveling Road Show Van



iQpump eLearning Video

Defect Prevention



Yaskawa manufacturing processes are designed to prevent defects. Production associates have paperless on-line resources at their workstations, providing highly detailed and up-to-date work instructions for every process step. Practice mechanisms are available in the Kaizen center for them to improve their assembly skills. Complex assemblies are made simple with the use of animations and video.

These processes enable us to approach our ultimate goal of zero-defect manufacturing.

Product Qualification/Testing

No other manufacturer puts its products through as many tests, or as arduous a testing process as Yaskawa. All printed circuit boards are functionally tested while under power. All Yaskawa products are 100% tested under full current. Yaskawa conducts its own product qualification testing in its ISO certified test lab. Products are tested not only under normal spec conditions, but also for the following:

- Extreme Temperature/ Humidity
- Vibration
- Package Drop
- Input Voltage Tolerance
- Noise Immunity
- Electrical Insulation Stress
- Under/Over-Voltage Protection
- Momentary Power Loss
- Output Short Circuit Protection
- Overload Protection
- Ground Fault Protection
- Washdown Test
- Input/Output Phase Loss Test
- Power ON/OFF & Start up Iterations



iQpump Micro NEMA-4X Washdown Test

Packages for any Environment

NEMA 1 Packages for iQpump1000

Yaskawa offers a standard NEMA 1 (UL Type 1) package for iQpump and configured units. All units are UL rated, with the configured packages built to UL 508A (Industrial Control Panel) standards. Installation, setup, service, and quick delivery have all been considered in these package designs.



NEMA 12 Packages for iQpump1000



iQpump configured packages are available with a NEMA 12 (UL Type 12) enclosure option. Fans, when required, are provided with Type 12 rated filters to maintain a Type 12 rating on the enclosure.

Standard Construction Features include:

- 12 Gauge Steel
- Whole Door Gasket
- Lifting Eyes
- Padlock Hasp
- Integral ¼ Turn Door Latches
- Removable Air Filter from Outside of Cabinet

NEMA 3R Packages for iQpump1000 and iQpump Micro

iQpump1000 and iQpump Micro configured packages are also offered with a NEMA 3R (UL Type 3R) enclosure option.

This enclosure is able to be installed in direct sunlight without the need for additional cooling or sunshade protection.

Standard Construction Features include:

- 12 Gauge Steel
- Whole Door Gasket
- Brass Hinges
- Lifting Eyes
- Stainless Steel Hardware
- Padlock Hasp
- Integral ¼ Turn Door Latches
- UV/Type 3R Keypad Membrane
- Sun Reflective White Powder Coat Paint



Fully Engineered Packages for iQpump1000



Both end users and OEM customers have come to rely on our custom product engineering capabilities. These products are based off of our standard configurations but can evolve into a totally customized package.

Engineered packages include:

- Redundant Drive Packages
- 12 or 18 Pulse Configurations
- Soft Start Bypass Packages
- Integrated Trap Filter Packages
- Multiple Motor Configurations

Engineered packages can be provided as NEMA 1, 12 or 3R. They are supported with custom engineered drawings and documentation.

Simplex Pump System

iQPUMP Micro

iQPUMP 1000

Overview

The most common applications are simplex (single pump) constant pressure and pump down level control. The iQpump is an easy investment choice with preset application macros, dedicated pump control features, and pump system protection.

PRODUCT FEATURES

- ▶ Sleep Mode Minimum Flow Protection
- ▶ No Flow / Deadhead Protection
- ▶ Submersible Motor Thrust Bearing Control
- ▶ Automatic System Restart
- ▶ Sleep Boost
- ▶ Low and High Pressure Feedback Detection
- ▶ Impeller Anti-jam Protection
- ▶ Power Loss Utility Start Delay Timer
- ▶ Loss of Prime (LOP) / Pump Dry-Run Protection
- ▶ Pre-Charge Control (Controlled Pipe Fill)
- ▶ * Constant Pressure with Well Drawn Down Control
- ▶ * Optional Dual Transducer Feedback for Redundancy
- ▶ * Impeller De-scaling / De-ragging Control

** Not Supported with iQpump Micro*

Examples of Simplex Systems

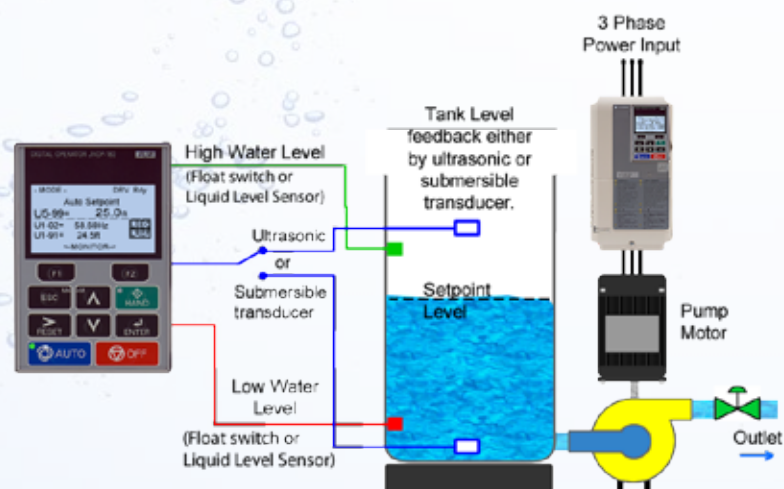
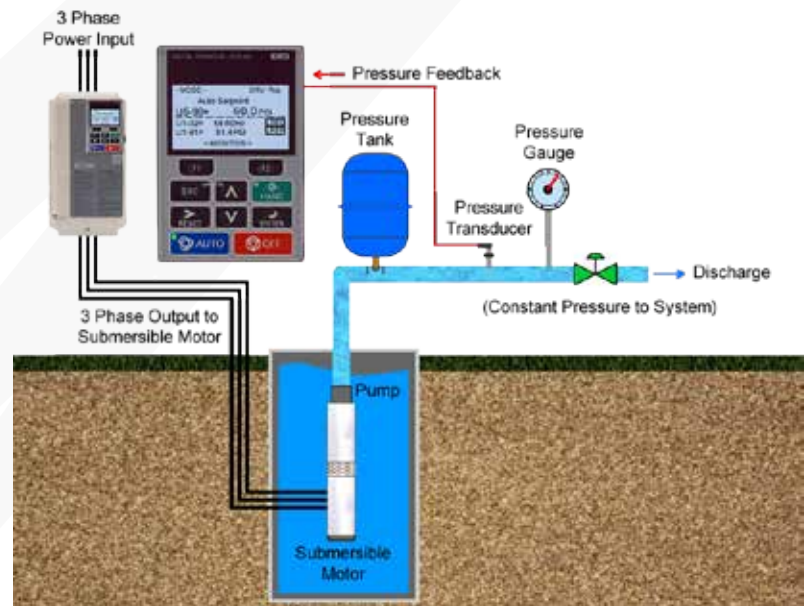

Software Features

iQPUMP Micro

iQPUMP 1000

Sleep Mode Minimum Flow Protection

Protects and shuts down the pump at low speeds or in low flow conditions.

No Flow / Deadhead Protection

Detects changes in pressure and flow when the system has been closed off via mechanical valves or restrictions. If a system is not protected from this condition, the water within the pump can vaporize, building up excessive heat that can damage the pump and the discharge piping.

Submersible Motor Thrust Bearing Control

Protects the bearings of submersible pump motors by ensuring proper start-up speeds and times.

Automatic System Restart

Programmable timers allow iQpump to automatically restart the system in Auto Mode for faults relating to brown outs, loss of power, and pump specific faults.

Loss of Prime (LOP) / Pump Dry-Run Protection

Loss of prime protection is a feature protecting the pump and motor from damage caused by running the pump without water. If a pump were to lose prime and continue to operate without water moving through the pump, the pump would develop heat, which would eventually damage the pump seal, motor, pipe manifold and related components.

Low and High Pressure Feedback Detection

iQpump continuously monitors the system feedback device to provide a warning alarm or fault based on the programmed level.

Impeller Anti-Jam Automatic Control

Provides a method for the iQpump to detect high current and attempt to expel corrosion or solids which are impeding the pump impeller. The system will perform a quick reversal to try and dislodge a jam.

Power Loss Utility Start Delay Timer

Used in conjunction with "Automatic Restart", a programmable timer will delay starting to allow for multiple pumps to sequence start on loss of power. This function ensures that the power system is not stressed when utility power has returned and pump system is automatically restarted.

Sleep Boost

Intended for use with a pressure tank, iQpump boosts the set pressure prior to shutdown, extending the pump's sleep time, reducing cycling, and saving energy.



20 HP Submersible Pump Control for Irrigation.

Pre-Charge Control (Controlled Pipe Fill)

This programmable feature eliminates water hammer and extends system life by gradually filling a pipeline before normal full pressure and flow operation. Pump motor speed can be controlled with a system timer, level or pressure control device to indicate when normal operation may begin.

* Constant Pressure with Well Draw Down Control

This function allows iQpump to control constant pressure when there is adequate water in the well, while monitoring a second down hole transducer for water level. If the water level drops below user settings, iQpump reduces pump speed to maximize well output. System will return automatically to normal operation when well water is recharged to an adequate level.

* Secondary Transducer Backup

This option used for Simplex control allows for a secondary backup transducer to be automatically used if the main transducer has failed. Keypad text message will alert what feedback transducer is being used.

** Not Supported with iQpump Micro*

Overview

iQpump has enhanced software not available in standard variable frequency drives, allowing for multiple drives to operate as a coordinated system. This allows pump system engineers the ability to add more modular pump systems together (Duplex, Triplex, etc.) to meet customer specifications and minimize cost by eliminating external control via PLC's and HMI's.

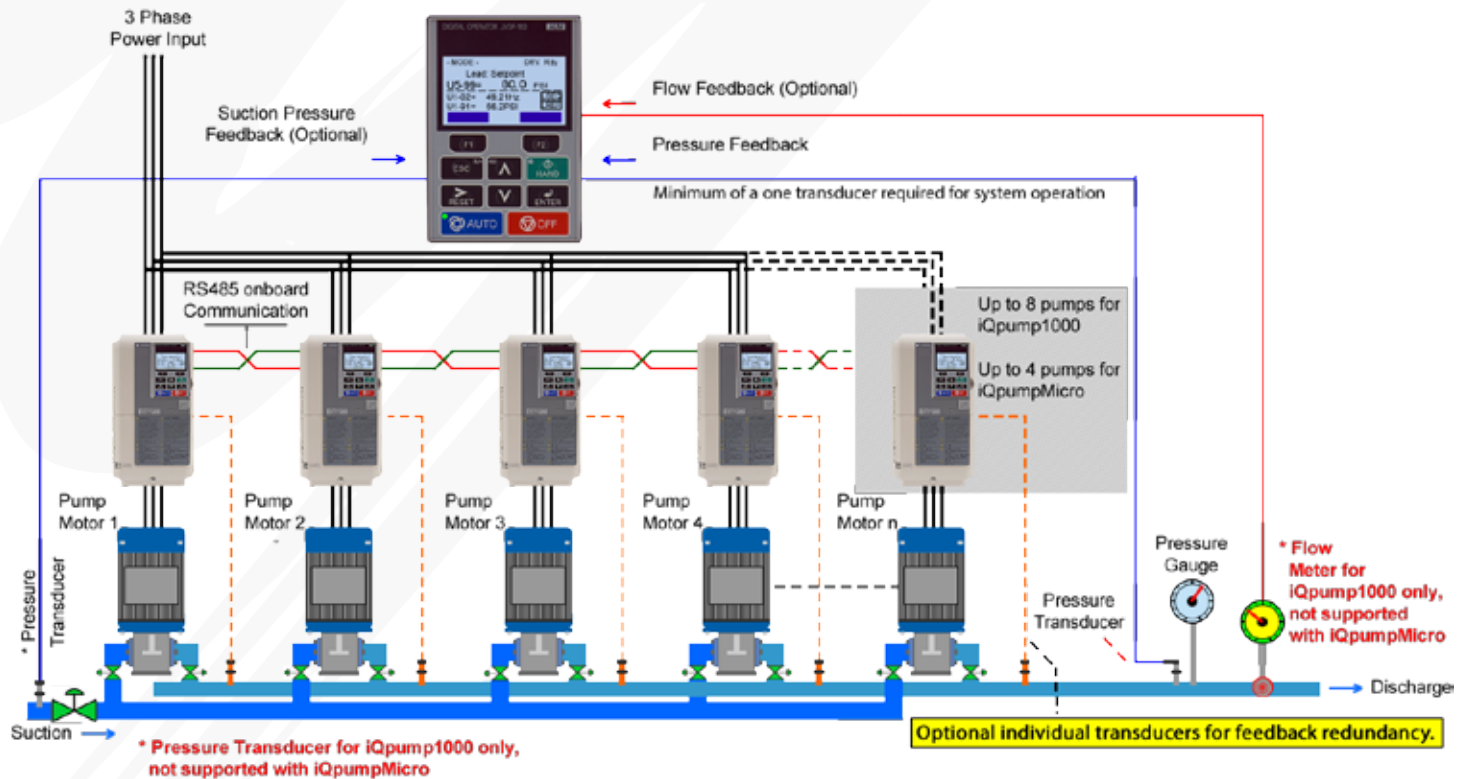

PRODUCT FEATURES

- ▶ Pump Alternation
- ▶ Pump and Drive Redundancy
- ▶ Transducer Feedback Redundancy
- ▶ Pump Run Priority Selection
- ▶ Jockey Pump Control
- ▶ Pump Stage and De-Stage
- ▶ Lag Pump Lead Speed Follower Mode

Application Notes

- Automatically alternates all pumps with a system programmable timer to provide even mechanical pump wear.
- Configurable transducer feedback settings to provide redundant backup if failure occurs.
- With the use of an optional suction transducer, all iQpump's will monitor inlet pressure with programmable PSI settings for faults, alarms and station controlled shutdown.
- Digital switch inputs for Low Suction / Low City Pressure / Low Water in Break Tank can be configured with selectable keypad message to match application.
- With the use of an optional flow input, all iQpump's can be configured to control staging and de-staging of lag pumps on GPM.

Software Features



Pump Alternation

Whether it's a duplex or a quadplex system, the pumps will be exercised evenly to ensure that they receive equal run times, thereby increasing the life cycle of the pumps and motors.

Pump and Drive Redundancy

If a drive or pump fails during operation or is taken out of service for maintenance, the remaining pumps continue to operate. The other drives on the network will automatically recognize when the drive and pump are restored to active healthy status and put them back into the pump rotation.

Transducer Feedback Redundancy

Systems can be configured using multiple transducers on the discharge allowing for redundancy. A minimum of one transducer is required for system operation.

Jockey Pump Control

Pressure booster systems that use a jockey pump to maintain minimum water flow with larger secondary booster pumps for peak demands require the jockey pump to always be defined as the lead pump. The larger booster pumps will alternate based on time or run cycle for even pump wear.

Lag Pump Lead Speed Follower Mode

When enabled, all lag iQpump drives will follow the main output speed (Hz or RPM) of the lead iQpump, thereby allowing all lead and lag pumps to run at the same speed for better system efficiency.

Pump Stage and De-Stage

System dynamics and pump curves will determine the best method of pump staging and de-staging. The user can select a variety of methods such as: Pump Output Speed, Pressure Differential to Setpoint, Combination of Output Speed and Differential Pressure, and Flow Rate using an in-line flow meter.



Triplex Booster System for New Jersey Hospital

Typical Multiplex Keypad Messages

The iQpump LCD keypad (recommended option on iQpump Micro) will provide the user with all the necessary system status operation and pump fault messages to ensure that service operators can efficiently monitor and diagnose any condition.



iQpump is in Off Mode (stopped) and has not been given an Auto Run command. Drive is taken out of the running queue.

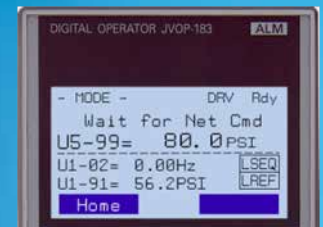

iQpump is in Auto Mode and waiting for a run command from the network.



iQpump is in Auto Mode and is the Lead pump.



iQpump is in Auto Mode and when a new Lead pump is staged, the Lag pump will be locked at a fixed speed.

Constant Speed Lag Pump Multiplexing for iQpump1000 ONLY



Overview

Many agricultural farms use multiple large verticle turbine pumps to provide pressurized water to large pivot irrigation systems. Applying a VFD to each of the booster pumps on these systems may not be practical. However, iQpump, using it's on-board digital outputs, can control up to 5 lag pump starters from a single VFD to maintain pressure by staging and de-staging the lag pumps.

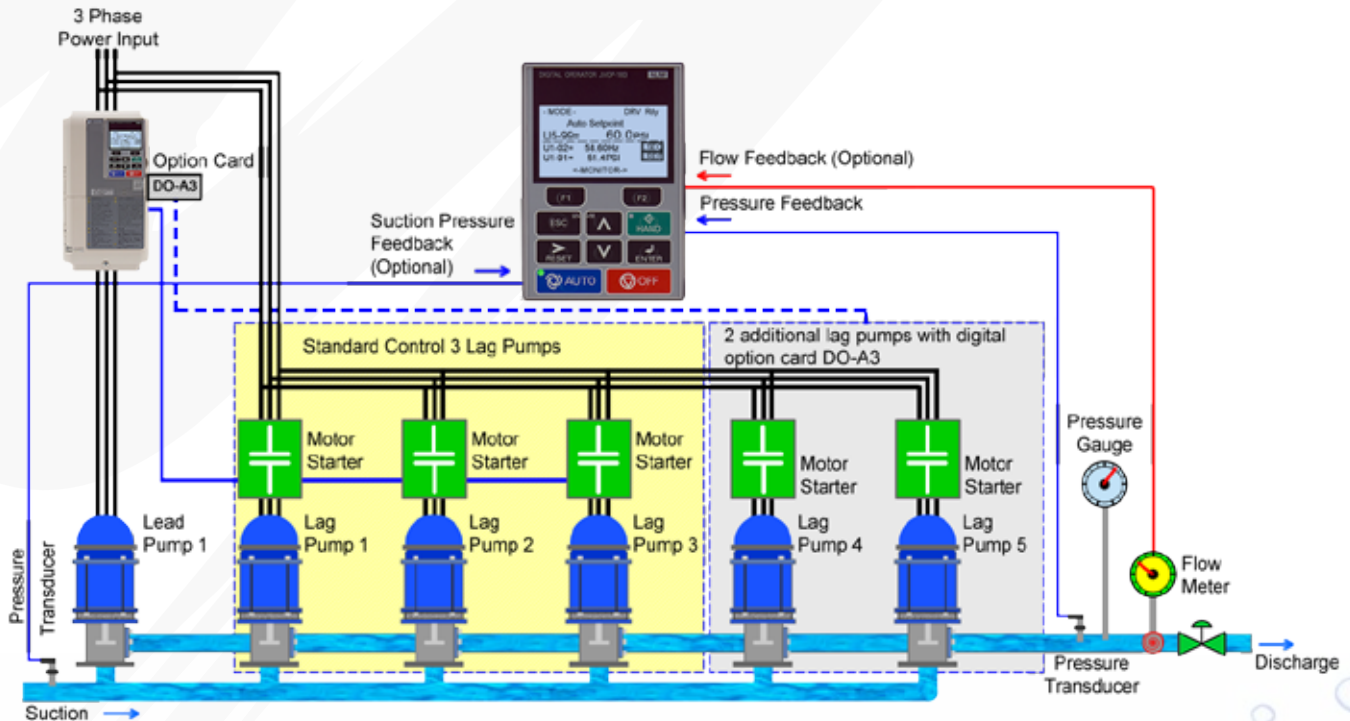

APPLICATION REQUIREMENTS

- ▶ Inlet Suction Control
- ▶ Speed Reduction "Go To Speed" After Lag Pump Staging
- ▶ Setpoint Boost After De-staging
- ▶ Low Flow and High Flow (GPM) Protection
- ▶ Flow Meter Data Logging
- ▶ Lube Pump Control
- ▶ Hard Current Limit
- ▶ Back Spin Timer
- ▶ High Discharge Pressure Lag Pump Quick de-Staging

Application Notes

- Automatically starts and stops up to 5 Lag pumps based on the system demand, and will automatically stage and de-stage the booster pumps.
- Alternation of lag pumps to provide even wear.
- Allows a single lag pump to be selected during Pre-Charge (Pipe Fill) to reduce fill rate time.
- For large water consumers, acre-feet can be selected for water accumulation units.
- When the discharge pressure exceeds a high level setting, all running lag pumps will be quickly de-staged to prevent unsafe high pressure conditions.
- When using Pre-Charge, Lag Pump Staging and De-Staging functions, the drive's keypad will provide a message of time remaining before pre-charge is finished and/or time remaining before lag pumps are to stage and de-stage.



Inlet Suction Control

iQpump, when installed with an inlet suction transducer, will monitor a suction pressure drop to a programmed suction pressure setpoint. The iQpump seamlessly switches over and controls suction pressure to keep the system running efficiently. If the inlet pressure returns to the suction pressure setpoint at any time, the iQpump will switch back to controlling outlet pressure. A suction pressure alarm/fault detection is available if the suction pressure drops below the Low Suction Pressure Detection Level for more than the Low Suction Pressure Detection Time.

Speed Reduction “Go To Speed” After Lag Pump Staging

This feature will force the lead iQpump, when in VTC mode, to operate at a lower fixed speed for a specified amount of time whenever a lag pump is staged on. This is to dampen the shock loading of a lag pump starting across the line to the system.

Setpoint Boost After De-staging

This feature will automatically boost the auto setpoint pressure to a new specified incremental amount for a programmable time whenever a pump is de-staged. This allows the lead iQpump, when in VTC mode, to accelerate more quickly to lessen the pressure drop on the system of a lag pump that is being de-staged.

Low Flow and High Flow (GPM) Protection

iQpump continuously monitors the system flow signal feedback to provide a warning alarm or fault based on the programmed level.

Flow Meter Data Logging

Through a secondary analog or pulse train input, a flow sensor can be connected inline with the pump system back to iQpump to read and accumulate total system flow to report to authorities. The system can be configured to detect “No Flow” and switch to “Sleep” on low demand.

Lube Pump Control

Designed for pumps that require pre-lubrication before each start. Digital output will energize a solenoid valve for a programmable time before starting, allowing for lubrication each time the pump is started.

Hard Current Limit

As the pump impeller wears over time, it changes the efficiency of the pump. Therefore, in order to maintain a constant pressure or flow, the pump speed will increase, resulting in greater motor current. This increase can cause the drive to trip on nuisance motor overload (OL). By setting in a hard motor current limit (not to exceed), the drive will reduce the output speed automatically to keep the system running smoothly as the impeller wears to keep the system from overloading.

Back Spin Timer

After Stop or Hand command, the drive will not restart until timer expires, allowing the water column to flow back down the well.

High Feedback Quick De-Stage



This feature will quickly de-stage a lag pump if the system feedback reaches a programmable level.



Quadplex River Booster System.



iQpump Micro vs. iQpump1000

Hardware Comparison

Features	 iQpump Micro	 iQpump1000
Voltage / HP Range	1 - 5HP 200 - 240V 1-Phase 1 - 25HP 200 - 240V 3-Phase 1 - 25HP 380 - 480V 3-Phase	1 - 175HP 200 - 240V 3-Phase 1 - 500HP 380 - 480V 3-Phase 2 - 250HP 500 - 600V 3-Phase
Real Time Clock	With Optional Remote H-O-A Operator Installed	Standard (Mounted on Drive)
H-O-A Operator	Option (Externally Mounted)	Standard (Mounted on Drive)
Transducer Power Supply	24V @ 30mA	24V @ 150mA
Analog Inputs	Qty 1 - Non-Programmable 0-10VDC Qty 1 - Programmable 0-10VDC or 4-20mA	Qty 3 - Programmable 0-10VDC or 4-20mA
Analog outputs	Qty 1 - Programmable 0-10VDC	Qty 2 - Programmable 0-10VDC or 4-20mA
Digital Inputs	7 Programmable	8 Programmable
Digital Outputs	Qty 1 - Form C Fault Relay Programmable Qty 2 - Programmable Photo-Couplers	Qty 1 - Form C Fault Relay (Non-Programmable) Qty 1 - Form C Programmable Relay Qty 2 - Form A Programmable Relay
Pulse Input	Not Used	Standard
Expansion I/O Adapters	Not Available	2 Additional Programmable Analog Outputs 2 Additional Programmable Digital Outputs
Standard Communications	RS-485/422	RS-485/422
Communications Network Options	Not Available	EtherNet/IP Modbus TCP/IP PROFIBUS-DP PROFINET DeviceNet MetaSys Apogee BACnet LonWorks

iQpump Micro vs. iQpump1000

Software Comparison

Features	 iQpump Micro	 iQpump1000
Pump Control Configurations (P1-01 Group):		
Simplex	✓	✓
Drive to Drive Multiplexing	Up to 4 Pumps	Up to 8 Pumps
Simplex with Constant Speed Lag Multiplexing (VTC Mode)	✗	✓
Pre-Programmed Application Macros (A1-03 Group):		
Constant Pressure	✓	✓
Pump Down Constant Level	✓	✓
General Purpose Mode - External Run and Speed Reference	✓	✓
Submersible Motor General Purpose Mode Using Digital Operator	✓	✓
Geothermal Mode	✗	✓
VTC (Vertical Turbine) Pressure Control with Lag Pump Multiplexing	✗	✓
Pump Specific Software Features:		
Selectable Engineering System Units	✓	✓
Sleep Mode / Minimum Flow	✓	✓
Start Level / Drawdown	✓	✓
Hand Mode Control Operations	✓	✓
Minimum Pump Speed	✓	✓
Transducer feedback Scaling	✓	✓
No Flow / Deadhead Protection	✓	✓
Submersible Thrust Bearing Control	✓	✓
Automatic Fault Restarts for Drive and Pump Protection	✓	✓
Sleep Boost	✓	✓
Low and High Feedback Detection	✓	✓
Low and High Water Float Inputs	✓	✓
Pump Over Cycle Protection	✓	✓
Impeller Anti-jam Protection	✓	✓
Loss of Prime (LOP) / Well Dry Run	✓	✓
Automatic Power Loss Utility Start Delay	✓	✓
Broken Pipe Protection	✓	✓
Transducer Feedback Loss	✓	✓
Transducer Feedback Loss with Programmable GOTO speeds	✓	✓
Pre-Charge / Controlled Pipe Fill	✓	✓
Hard Current Limit	✓	✓
Over Torque Detection	✓	✓
Pump Back Spin Timer	✓	✓
Single Phase Loss Speed Foldback Protection	✓	✓
Multiplex Drive to Drive Pump Setup and Adjustments	✓	✓
Pulse Input for Flow Meter Control and Water Usage Data Logging	✗	✓
Pump De-Scale / De-Ragging	✗	✓
Measuring Water Well Drawdown via transducer with Constant Discharge Pressure	✗	✓
Inlet Suction Pressure Control via Transducer Feedback	✗	✓
Real Time Clock Sequence Drive On/Off Run Timers	✗	✓
Secondary Transducer Input for Redundancy in Simplex and Multiplex Mode	✗	✓

✓ = Supported ✗ = Not Supported

iQpump Micro Models and Specifications



Model Number

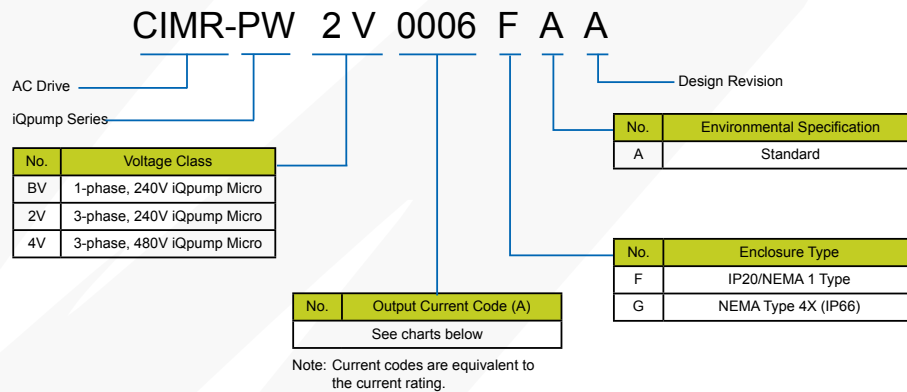

240V - Dedicated Single-Phase Models

Model Number	Dedicated Single-Phase, 240V		Dimensions (in.)					
			NEMA 1 (CIMR-PWBV-XXXX-FAA)			NEMA-4X (CIMR-PWBV-XXXX-GAA)		
	Max Capacity (HP)	Rated Current (A)	Height	Width	Depth	Height	Width	Depth
CIMR-PWBV0006	1	6.0	5.89	4.25	6.47	10.04	7.36	9.25
CIMR-PWBV0010	3	9.6	5.89	4.25	7.12	10.04	7.36	9.25
CIMR-PWBV0012	3	12.0	6.02	5.51	7.48	10.04	7.36	9.25
CIMR-PWBV0018	5	17.5	6.02	6.69	8.15	Not Available		

240V - Three-Phase Models

Model Number	3-Phase, 240V Ratings		Single-Phase, 240V De-Rate (NEMA 1, 4X) - (Continuous Full Power)				Dimensions (in.)					
			Without Additional Input Reactor		With Additional Input Reactor		NEMA 1 (CIMR-PWBV-XXXX-FAA)			NEMA-4X (CIMR-PWBV-XXXX-GAA)		
	Max Capacity (HP)	Rated Current (A)	Max Capacity (HP)	Rated Current (A)	Max Capacity (HP)	Rated Current (A)	Height	Width	Depth	Height	Width	Depth
CIMR-PW2V0006	1.5	6.0	1	4.9	1	4.9	5.89	2.68	6.10	8.74	6.38	7.28
CIMR-PW2V0010	2 / 3	9.6	1.5	6.8	1.5	6.8	5.89	4.25	6.14	10.04	7.36	9.25
CIMR-PW2V0012	3	12.0	2	7.5	2	7.5	5.89	4.25	6.47	10.04	7.36	9.25
CIMR-PW2V0020	5	19.6	2	9.7	3	12.3	6.02	5.51	6.69	10.04	7.36	9.25
CIMR-PW2V0030	7.5 / 10	30	2	7.5	3	15.2	10.0	5.51	6.57	16.54	11.42	12.01
CIMR-PW2V0040	10	40	5	16.7	5	21.0	10.0	5.51	6.57	16.54	11.42	12.01
CIMR-PW2V0056	15 / 20	56	5	23.4	7.5	27.7	11.42	7.09	7.48	16.54	11.42	12.01
CIMR-PW2V0069	25	69	7.5	25.8	10	30.8	14.09	8.66	8.42	18.31	11.42	12.01

480V- Three-Phase Models

Model Number	3-Phase, 480V Ratings		Single-Phase, 480V De-Rate (NEMA 1, 4X) - (Continuous Full Power)				Dimensions (in.)					
			Without Additional Input Reactor		With Additional Input Reactor		NEMA 1			NEMA-4X		
	Max Capacity (HP)	Rated Current (A)	Max Capacity (HP)	Rated Current (A)	Max Capacity (HP)	Rated Current (A)	Height	Width	Depth	Height	Width	Depth
CIMR-PW4V0002	1	2.1	0.5	1.3	0.5	1.7	5.89	4.25	4.96	8.74	6.38	7.28
CIMR-PW4V0004	2	4.1	1	2.4	1	2.8	5.89	4.25	6.47	8.74	6.38	7.28
CIMR-PW4V0005	3	5.4	1.5	3.5	2	3.9	5.89	4.25	7.12	10.04	7.36	9.25
CIMR-PW4V0007	3	6.9	1.5	3.5	2	5.4	5.89	4.25	7.12	10.04	7.36	9.25
CIMR-PW4V0009	5	8.8	2	5.1	3	5.5	5.89	4.25	7.12	10.04	7.36	9.25
CIMR-PW4V0011	7.5	11.1	3	5.5	3	7.5	6.02	5.51	6.69	10.04	7.36	9.25
CIMR-PW4V0018	10	17.5	2	4.5	5	8.7	10.0	5.51	6.57	16.54	11.42	12.01
CIMR-PW4V0023	15	23	3	5.5	5	10.5	10.0	5.51	6.57	16.54	11.42	12.01
CIMR-PW4V0031	20	31	3	7.9	7.5	13.5	11.42	7.09	6.69	16.54	11.42	12.01
CIMR-PW4V0038	25	38	5	11.3	10	16.1	11.42	7.09	7.48	16.54	11.42	12.01

Model Number

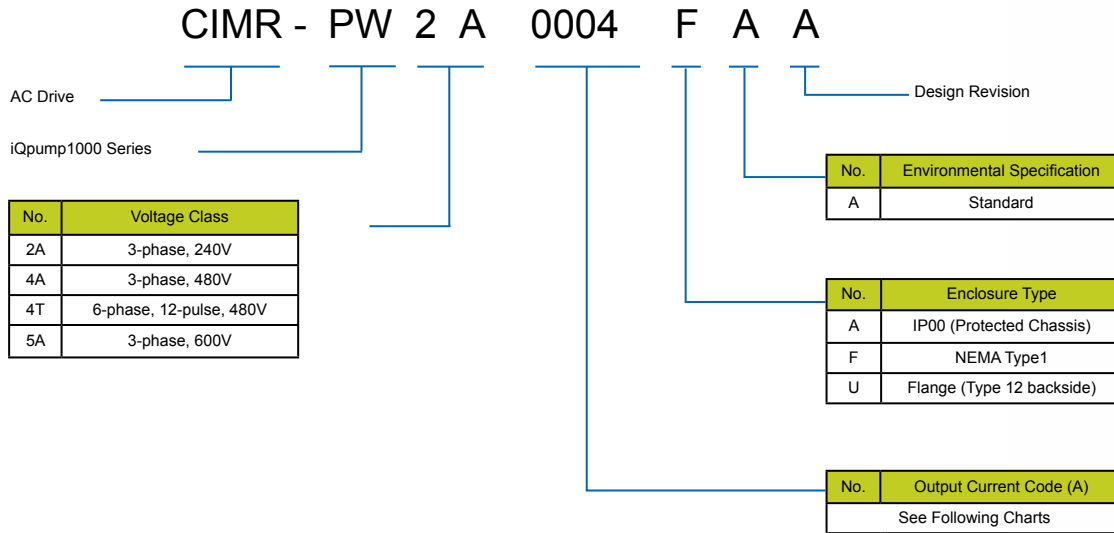

240V - Three-Phase Models

Model Number	3-Phase Input, 240V		Single-Phase Input, 240V; 3-Phase Output, 208-230V						iQpump1000 Dimensions			Weight (lb)	
	Rated Current (A)	Max Capacity (HP)	Sizing Method A (Continuous Full Power) ^(A)				Sizing Method B (86% max power of connected motor size) ^(B)						
			Without Additional Input Reactor		With Additional Input Reactor		Rated Current (A)	Max Capacity (HP)					
			Rated Current (A)	Max Capacity (HP)	Rated Current (A)	Max Capacity (HP)			Height	Width	Depth	NEMA 1	Protected Chassis
CIMR-PW2A0004_AA	3.5	3/4	1.7	1/3	2.4	1/2	2.4	1/2	12.06	5.51	5.79	7.3	--
CIMR-PW2A0006_AA	6	1	3.5	3/4	3.5	3/4	4.6	1	12.06	5.51	5.79	7.3	--
CIMR-PW2A0008_AA	8	2	4.6	1	4.6	1	4.6	1	12.06	5.51	5.79	7.5	--
CIMR-PW2A0010_AA	9.6	3	4.6	1	4.6	1	6.6	1.5	12.06	5.51	5.79	7.5	--
CIMR-PW2A0012_AA	12	3	6.6	1.5	7.5	2	7.5	2	12.06	5.51	5.79	7.5	--
CIMR-PW2A0004_AA	17.5	5	7.5	2	10.6	3	10.6	3	12.06	5.51	6.46	8.2	--
CIMR-PW2A0004_AA	21	7.5	7.5	2	10.6	3	10.6	3	12.06	5.51	6.46	8.2	--
CIMR-PW2A0004_AA	30	10	10.6	3	10.6	3	17	5	12.06	5.51	6.57	9.3	--
CIMR-PW2A0004_AA	40	15	10.6	3	17	5	17	5	12.06	5.51	6.57	9.3	--
CIMR-PW2A0004_AA	56	20	17	5	24	7.5	24	7.5	13.38	7.09	7.36	13.0	--
CIMR-PW2A0004_AA	69	25	24	7.5	31	10	31	10	15.47	8.66	7.76	20.1	--
CIMR-PW2A0004_AA	81	30	31	10	46	15	46	15	15.47	8.66	7.76	22.0	--
CIMR-PW2A0004_AA	110	40	31	10	31	10	46	15	21.37	10.00	10.16	50.7	46.2
CIMR-PW2A0004_AA	138	50	46	15	46	15	59	20	24.52	10.98	10.16	61.7	55.0
CIMR-PW2A0004_AA	169	60	59	20	59	20	75	25	30.08	12.95	11.14	90.2	81.4
CIMR-PW2A0004_AA	211	75	75	25	75	25	88	30	30.08	12.95	11.14	92.4	83.6
CIMR-PW2A0004_AA	250	100	88	30	88	30	114	40	37.80	17.95	12.99	191.8	167.6
CIMR-PW2A0004_AA	312	125	114	40	114	40	143	50	37.80	17.95	12.99	191.8	176.4
CIMR-PW2A0004_AA	360	150	143	50	143	50	169	60	45.98	19.84	13.78	233.7	216.1
CIMR-PW2A0004_AA	415	175	169	60	169	60	211	75	45.98	19.84	13.78	233.7	218.3

(A) Use single phase sizing method A for applications requiring more than 87% motor power (more than 95% speed for variable torque) for any length of time.

(B) Use single phase sizing method B for applications requiring no more than 87% motor power (no more than 95% speed for variable torque).

iQpump1000 Models and Specifications



480V - Three-Phase Models

Model Number	3-Phase Input, 480V		Single-Phase Input, 480V; 3-Phase Output, 460V						iQpump1000 Dimensions			Weight (lb)	
	Rated Current (A)	Max Capacity (HP)	Sizing Method A (Continuous Full Power) ^(A)				Sizing Method B (86% max power of connected motor size) ^(B)						
			Without Additional Input Reactor		With Additional Input Reactor		Rated Current (A)	Max Capacity (HP)					
			Rated Current (A)	Max Capacity (HP)	Rated Current (A)	Max Capacity (HP)			Height	Width	Depth	NEMA 1	Protected Chassis
CIMR-PW4A0002_AA	2.1	1	0.8	1/3	1.1	1/2	0.8	1/3	12.06	5.51	5.79	7.3	--
CIMR-PW4A0004_AA	4.1	2	1.6	3/4	2.1	1	2.1	1	12.06	5.51	5.79	7.3	--
CIMR-PW4A0005_AA	5.4	3	2.1	1	3	1.5	3	1.5	12.06	5.51	5.79	7.3	--
CIMR-PW4A0007_AA	6.9	4	3.0	1.5	3.4	2	3.4	2	12.06	5.51	6.46	8.2	--
CIMR-PW4A0009_AA	8.8	5	3.4	2	4.8	3	4.8	3	12.06	5.51	6.46	8.2	--
CIMR-PW4A0011_AA	11.1	7.5	3.4	2	4.8	3	4.8	3	12.06	5.51	6.46	8.2	--
CIMR-PW4A0018_AA	17.5	10	4.8	3	4.8	3	7.6	5	12.06	5.51	6.57	9.3	--
CIMR-PW4A0023_AA	23	15	4.8	3	7.6	5	7.6	5	12.06	5.51	6.57	9.3	--
CIMR-PW4A0031_AA	31	20	11	7.5	11	7.5	14	10	13.38	7.09	6.88	12.5	--
CIMR-PW4A0038_AA	38	25	11	7.5	14	10	14	10	13.38	7.09	7.36	13.0	--
CIMR-PW4A0044_AA	44	30	14	10	14	10	21	15	15.47	8.66	7.76	20.1	--
CIMR-PW4A0058_AA	58	40	21	15	21	15	27	20	18.65	10.37	10.16	50.6	50.6
CIMR-PW4A0072_AA	72	50	27	20	27	20	34	25	20.62	11.35	10.16	59.4	59.4
CIMR-PW4A0088_AA	88	60	27	20	27	20	34	25	25.16	13.32	10.27	85.8	79.2
CIMR-PW4A0103_AA	103	75	27	20	27	20	34	25	25.16	13.32	10.27	85.8	79.2
CIMR-PW4A0139_AA	139	100	52	40	52	40	65	50	30.08	12.95	11.14	99.0	90.2
CIMR-PW4A0165_AA	165	125	52	40	52	40	65	50	30.08	12.95	11.14	101	92.4
CIMR-PW4A0208_AA	208	150	65	50	65	50	77	60	37.80	17.95	12.99	191	174
CIMR-PW4A0250_AA	250	200	77	60	77	60	96	75	45.98	19.84	13.78	233	211
CIMR-PW4A0296_AA	296	250	96	60	96	75	124	100	45.98	19.84	13.78	246	224
CIMR-PW4A0362_AA	362	300	124	75	124	100	156	125	45.98	19.84	13.78	257	235
CIMR-PW4A0414_AA UUX000861 ^(C)	414	350	156	125	156	125	180	150	48.3	20.29	14.68	292	275
CIMR-PW4A0515_AA UUX000862 ^(C)	515	400	156	125	156	125	180	150	61.3	26.86	14.72	504	475
CIMR-PW4A0675_AA UUX000863 ^(C)	675	500 - 550	180	150	180	150	240	200	61.3	26.86	14.72	515	486
CIMR-PW4A0930_AA	930	600 - 800	Consult Yaskawa Factory						80.4	50.2	14.73	1394	1195
CIMR-PW4A1200_AA	1200	900 - 1000	Consult Yaskawa Factory						80.4	50.2	14.73	1420	1221

(A) Use single phase sizing method A for applications requiring more than 87% motor power (more than 95% speed for variable torque) for any length of time.

(B) Use single phase sizing method B for applications requiring no more than 87% motor power (no more than 95% speed for variable torque).

(C) NEMA 1 Compatible kit for Single Phase operation.

iQpump1000 Models and Specifications



600V - Three-Phase Models

Model Number	3-Phase Input, 600V		Single-Phase Input, 600V; 3-Phase Output, 575V						iQpump Dimensions			Weight (lb)	
	Rated Current (A)	Max Capacity (HP)	Sizing Method A (Continuous Full Power) ^(A)				Sizing Method B (86% max power of connected motor size) ^(B)						
			Without Additional Input Reactor		With Additional Input Reactor		Rated Current (A)	Max Capacity (HP)					
			Rated Current (A)	Max Capacity (HP)	Rated Current (A)	Max Capacity (HP)			Height	Width	Depth	NEMA 1	Protected Chassis
CIMR-PW5A0003_AA	2.7	1 & 2	1.7	1	2.4	1.5	1.7	1	12.06	5.51	5.79	7.3	--
CIMR-PW5A0004_AA	3.9	3	2.4	1.5	2.7	2	2.7	2	12.06	5.51	5.79	7.3	--
CIMR-PW5A0006_AA	6.1	5	2.7	2	3.9	3	3.9	3	12.06	5.51	6.46	8.2	--
CIMR-PW5A0009_AA	9	7.5	3.9	3	6.1	5	6.1	5	12.06	5.51	6.46	8.2	--
CIMR-PW5A0011_AA	11	10	2.7	2	3.9	3	3.9	3	12.06	5.51	6.57	9.3	--
CIMR-PW5A0017_AA	17.5	15	6.1	5	6.1	5	9	7.5	13.38	7.09	7.36	13.0	--
CIMR-PW5A0022_AA	22	20	6.1	5	9	7.5	9	7.5	13.38	7.09	7.36	13.0	--
CIMR-PW5A0027_AA	27	25	9	7.5	11	10	11	10	15.47	8.66	7.76	20.1	--
CIMR-PW5A0032_AA	32	30	9	7.5	11	10	11	10	15.47	8.66	7.76	20.1	--
CIMR-PW5A0041_AA	41	40	17	15	17	15	22	20	20.62	11.35	10.16	59.4	59.4
CIMR-PW5A0052_AA	52	50	17	15	17	15	22	20	20.62	11.35	10.16	59.4	59.4
CIMR-PW5A0062_AA	62	60	27	25	27	25	32	30	30.08	12.95	11.14	99.0	90.2
CIMR-PW5A0077_AA	77	75	27	30	32	30	41	40	30.08	12.95	11.14	99.0	90.2
CIMR-PW5A0099_AA	99	100	32	30	32	30	41	40	30.08	12.95	11.14	99.0	90.2
CIMR-PW5A0125_AA	125	125	52	50	52	50	62	60	37.80	17.95	12.99	191	174
CIMR-PW5A0145_AA	145	150	52	50	52	50	62	60	37.80	17.95	12.99	191	174
CIMR-PW5A0192_AA	192	200	77	75	77	75	99	100	45.98	19.84	13.78	233	235
CIMR-PW5A0242_AA	242	250	77	75	77	75	99	100	45.98	19.84	13.78	257	235

(A) Use single phase sizing method A for applications requiring more than 87% motor power (more than 95% speed for variable torque) for any length of time.

(B) Use single phase sizing method B for applications requiring no more than 87% motor power (no more than 95% speed for variable torque).

We take quality personally at Yaskawa. Our drives and servo packages offer the highest MTBF in the world. The relationships we have with our customers ensure mutual benefits. The partnerships we cultivate with our distributors add value to the way we work with you. We hire great people and continuously train them to be able to serve your needs better. We deliver product on time. It works out of the box. We answer questions promptly and never say, "we can't."

To us, quality means doing everything we can to make our customer, partner, and employee experiences great.

We commit to that philosophy every day. We make it happen. We can because, to us,
IT'S PERSONAL.



Yaskawa America, Inc.
Drives & Motion Division

2121 Norman Drive South
Waukegan, IL 60085

1-800-YASKAWA (927-5292) • Local: 847-887-7000 • Fax: 1-847-887-7310

DrivesHelpDesk@yaskawa.com • www.yaskawa.com

Document BL.iQpump.01 01/20/2015 • © 2014-2015

