



### FEATURES

- No moving parts
- Durable
- Adjustable depth
- Hot-tap available
- Brass or stainless steel
- Immersibility available
- Reverse flow output available

### APPLICATIONS

- 3" - 48" pipe (up to 72" optional)
- Clean or "dirty" liquids
- Conductive liquids
- Municipal
- Industrial
- Irrigation

### GENERAL INFORMATION

The EX100/200-Series are adjustable depth insertion magmeters that fit 3" to 48" pipe (up to 72" optional). The complete lack of moving parts of the EX100/200-Series is the source of its reliability. Brass and stainless steel models withstand a variety of temperature, pressure, and chemical conditions. The EX-Series has no rotor to stop turning in dirty water and there are no bearings to wear out. Like all magmeters, when used in chemical injection applications, these meters should be installed upstream of the chemical line (or far enough downstream to allow complete mixing of fluids before the meter). Adapters mate with standard 1-1/2" (11x/21x) or 2" (15x/25x) FNPT threaded fittings such as saddles and weldolets which may be purchased either locally or from Seametrics.

A rapidly reversing magnetic field is produced in the lower housing. As the fluid moves through this field, a voltage is generated that is measured and translated into a frequency signal proportional to flow rate. This square wave signal can be sent directly to a PLC or other control or can be converted using any of the Seametrics family of indicators and converters.

A modular system of electronics can be installed directly on the flow sensor or mounted remotely. The FT430 (externally powered with pulse) and the FT440 (loop powered), both provide digital rate and total displays, as well as a programmable pulse; the FT440 also provides a 4-20 mA analog output. The AO55 is a blind analog (4-20 mA) transmitter. Programmable pulse for pump pacing is available with the PD10.

The "hot-tap" models (EX15x/25x) can be installed or serviced without shutting down the line by means of a 2" full-port isolation valve that comes with a nipple for installation on the pipe fitting; a bronze ball valve is standard, with a 316 stainless steel valve option if needed. In most circumstances, no special tool is required.

Reverse flow output and immersibility are optional.

## FEATURES

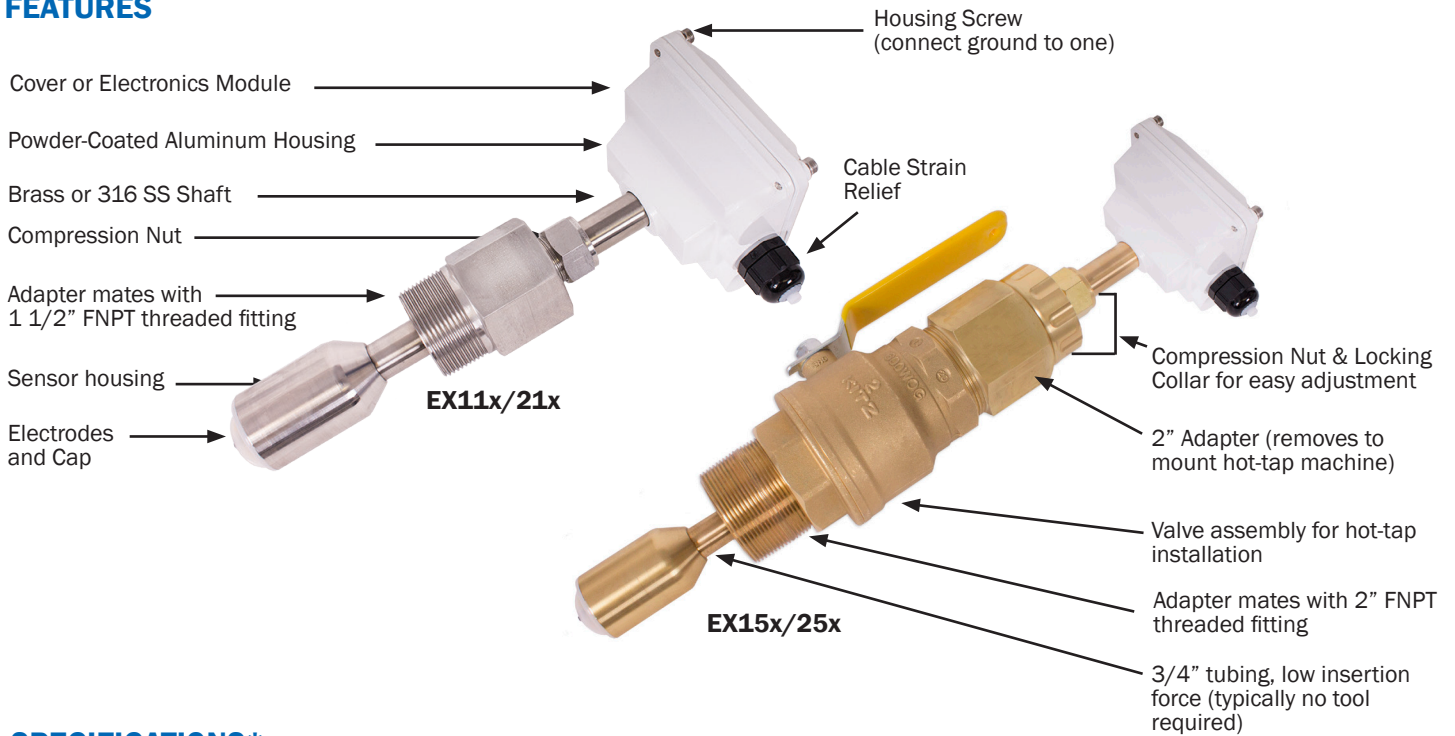

## SPECIFICATIONS\*

<b>Pipe Sizes</b>	3" to 48" (up to 72" optional)	
<b>Materials</b>	<b>Shaft/Fitting</b>	316 SS or Brass
	<b>Electrodes</b>	Hastelloy
	<b>Electrode Cap</b>	PVDF
	<b>Housing</b>	Cast powder-coated aluminum
	<b>Valve Assembly (15x/25x Only)</b>	Bronze (stainless optional) with bronze ball valve
	<b>O-Ring (15x/25x Only)</b>	EPDM
<b>Power</b>	<b>Full Power</b>	12-25 Vdc, 250 mA
	<b>Low Power</b>	12-25 Vdc, 40 mA average with 250 mA peaks
<b>Flow Range</b>	0.28 to 20 ft/sec (0.08 - 6.09 m/sec)	
<b>Fitting Size Required</b>	<b>EX11x/21x</b>	<b>EX15x/25x</b>
	1-1/2" FNPT	2" FNPT
<b>Temperature</b>	<b>Ambient</b>	0° to 160° F (-17° to 72° C)
	<b>Fluid</b>	32° to 200° F (0° to 93° C)
<b>Pressure</b>	200 psi (14 bar)	
<b>Minimum Conductivity</b>	20 microSiemens/cm	
<b>Calibration Accuracy</b>	+/- 1% of full scale	
<b>Output</b>	Square wave pulse, opto isolated, 500 Hz @ 20 ft/sec 6 mA max, 30 Vdc forward flow standard; reverse flow optional	
<b>Empty Pipe Detection</b>	Software, defaults to zero flow	
<b>Regulatory</b>	CE (Standard power only)	

\*Specifications subject to change • Please consult our website for current data ([www.seametrics.com](http://www.seametrics.com)).

## DIMENSIONS

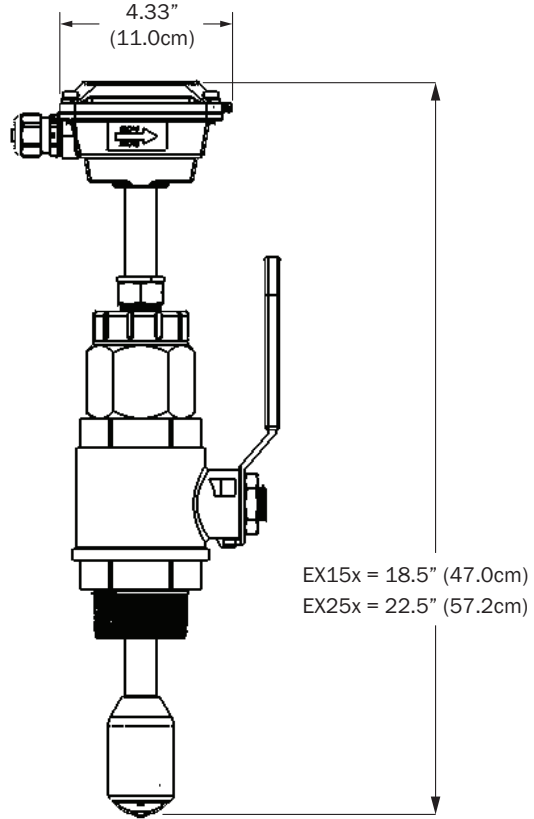
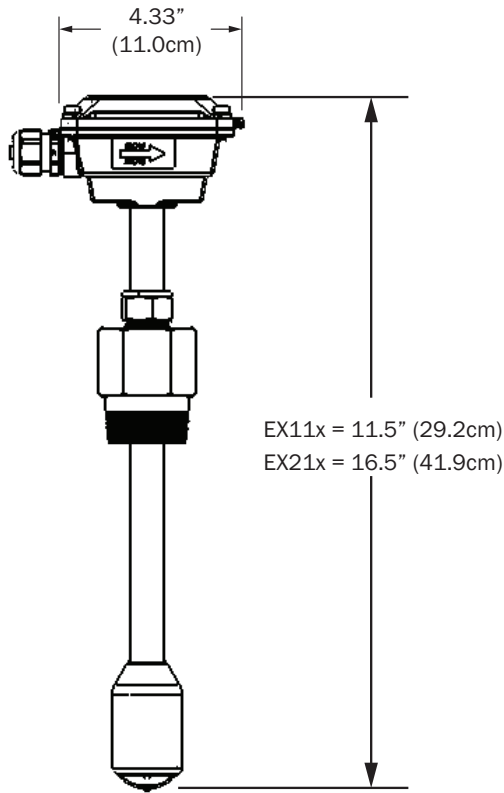

Flow Range (GPM)		
Nominal Pipe Size	Min. Flow	Max. Flow
3	6	440
4	11	783
6	25	1,762
8	44	3,133
10	69	4,895
12	99	7,050
14	134	9,596
16	175	12,533
18	222	15,863
20	274	19,584
24	395	28,200
30	617	44,064
36	888	63,452
48	1,580	112,804

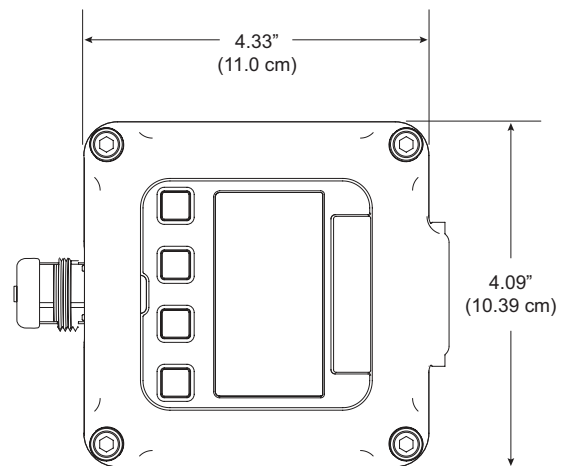

## HOW TO ORDER

	Description	Size	Sensor Material	Options (110/210)	Options (150/250)
<b>Sensor Only</b>	Sensor Only.	3" - 10" pipe = <b>EX110</b> 10" - 48" pipe = <b>EX210</b>	Brass = <b>B</b> 316 Stainless = <b>S</b>	Brass Adapter Fitting 2" NPT = <b>-02</b> SS Adapter Fitting 2" NPT = <b>-02</b> Reverse Flow Output = <b>-15</b> Brass Adapter 1 1/2" BSP = <b>-23</b> SS Adapter 1 1/2" BSP = <b>-24</b> Old Style Adapter 1 1/2" NPT = <b>-35</b> *Immersible = <b>-40</b> Low Power = <b>-50</b> 12" Extension (200 Series Only) = <b>-72</b>	316 SS Valve Assembly = <b>-08</b> No Valve Assembly = <b>-09</b> 316 SS Valve Assembly = <b>-08</b> Reverse Flow Output = <b>-15</b> *Immersible = <b>-40</b> Low Power = <b>-50</b> 12" Extension (200 Series Only) = <b>-72</b>
	<b>Hot Tap</b> 3" - 10" pipe = <b>EX150</b> 10" - 48" pipe = <b>EX250</b>				
<b>A055 Mounted on Sensor</b>	Blind 4-20 mA analog transmitter (A055) mounted on the sensor.	3" - 10" pipe = <b>EX112</b> 10" - 48" pipe = <b>EX212</b>	Brass = <b>B</b> 316 Stainless = <b>S</b>	Brass Adapter Fitting 2" NPT = <b>-02</b> SS Adapter Fitting 2" NPT = <b>-02</b> Reverse Flow Output = <b>-15</b> Brass Adapter 1 1/2" BSP = <b>-23</b> SS Adapter 1 1/2" BSP = <b>-24</b> Old Style Adapter 1 1/2" NPT = <b>-35</b> Low Power = <b>-50</b> 12" Extension (200 Series Only) = <b>-72</b>	316 SS Valve Assembly = <b>-08</b> No Valve Assembly = <b>-09</b> Reverse Flow Output = <b>-15</b> Low Power = <b>-50</b> 12" Extension (200 Series Only) = <b>-72</b>
	<b>Hot Tap</b> 3" - 10" pipe = <b>EX152</b> 10" - 48" pipe = <b>EX252</b>				
<b>FT430 Mounted on Sensor</b>	Rate & total indicator with pulse, externally powered (FT430) mounted on the sensor.	3" - 10" pipe = <b>EX113</b> 10" - 48" pipe = <b>EX213</b>	Brass = <b>B</b> 316 Stainless = <b>S</b>	Brass Adapter Fitting 2" NPT = <b>-02</b> SS Adapter Fitting 2" NPT = <b>-02</b> Reverse Flow Output = <b>-15</b> Brass Adapter 1 1/2" BSP = <b>-23</b> SS Adapter 1 1/2" BSP = <b>-24</b> Tamper Evident Kit = <b>-32</b> Old Style Adapter 1 1/2" NPT = <b>-35</b> Low Power = <b>-50</b> Non-resettable Total = <b>-64</b> 12" Extension (200 Series Only) = <b>-72</b> Hinged Display Cover = <b>-126</b>	316 SS Valve Assembly = <b>-08</b> No Valve Assembly = <b>-09</b> Reverse Flow Output = <b>-15</b> Tamper Evident Kit = <b>-32</b> Non-resettable Total = <b>-64</b> 12" Extension (200 Series Only) = <b>-72</b> Hinged Display Cover = <b>-126</b>
	<b>Hot Tap</b> 3" - 10" pipe = <b>EX153</b> 10" - 48" pipe = <b>EX253</b>				
<b>DL76 Mounted on Sensor</b>	Data logger (DL76) mounted on the sensor.	3" - 10" pipe = <b>EX116</b> 10" - 48" pipe = <b>EX216</b>	Brass = <b>B</b> 316 Stainless = <b>S</b>	Brass Adapter Fitting 2" NPT = <b>-02</b> SS Adapter Fitting 2" NPT = <b>-02</b> Reverse Flow Output = <b>-15</b> Brass Adapter 1 1/2" BSP = <b>-23</b> SS Adapter 1 1/2" BSP = <b>-24</b> Tamper Evident Kit = <b>-32</b> Old Style Adapter 1 1/2" NPT = <b>-35</b> Low Power = <b>-50</b> 12" Extension (200 Series Only) = <b>-72</b>	316 SS Valve Assembly = <b>-08</b> No Valve Assembly = <b>-09</b> Reverse Flow Output = <b>-15</b> Tamper Evident Kit = <b>-32</b> Low Power = <b>-50</b> 12" Extension (200 Series Only) = <b>-72</b>
	<b>Hot Tap</b> 3" - 10" pipe = <b>EX156</b> 10" - 48" pipe = <b>EX256</b>				
<b>PD10 Mounted on Sensor</b>	Pulse Divider (PD10) mounted on the sensor.	3" - 10" pipe = <b>EX118</b> 10" - 48" pipe = <b>EX218</b>	Brass = <b>B</b> 316 Stainless = <b>S</b>	Brass Adapter Fitting 2" NPT = <b>-02</b> SS Adapter Fitting 2" NPT = <b>-02</b> LMI Pump 4-pin Connector = <b>-06</b> Reverse Flow Output = <b>-15</b> Brass Adapter 1 1/2" BSP = <b>-23</b> SS Adapter 1 1/2" BSP = <b>-24</b> Old Style Adapter 1 1/2" NPT = <b>-35</b> 10 Ft. Cable for LMI Connector = <b>-37</b> Low Power = <b>-50</b> 12" Extension (200 Series Only) = <b>-72</b> Roytronic® Series-A 5-Pin Connector = <b>-106</b>	LMI Pump 4-pin Connector = <b>-06</b> 316 SS Valve Assembly = <b>-08</b> No Valve Assembly = <b>-09</b> Reverse Flow Output = <b>-15</b> 10 Ft. Cable for LMI Connector = <b>-37</b> Low Power = <b>-50</b> 12" Extension (200 Series Only) = <b>-72</b> Roytronic® Series-A 5-Pin Connector = <b>-106</b>
	<b>Hot Tap</b> 3" - 10" pipe = <b>EX158</b> 10" - 48" pipe = <b>EX258</b>				
<b>FT440 Mounted on Sensor</b>	Rate & total indicator with pulse & 4-20 mA output, loop powered (FT440) mounted on the sensor.	3" - 10" pipe = <b>EX119</b> 10" - 48" pipe = <b>EX219</b>	Brass = <b>B</b> 316 Stainless = <b>S</b>	Brass Adapter Fitting 2" NPT = <b>-02</b> SS Adapter Fitting 2" NPT = <b>-02</b> Reverse Flow Output = <b>-15</b> Brass Adapter 1 1/2" BSP = <b>-23</b> SS Adapter 1 1/2" BSP = <b>-24</b> Tamper Evident Kit = <b>-32</b> Old Style Adapter 1 1/2" NPT = <b>-35</b> Low Power = <b>-50</b> Non-resettable Total = <b>-64</b> 12" Extension (200 Series Only) = <b>-72</b> Hinged Display Cover = <b>-126</b>	316 SS Valve Assembly = <b>-08</b> No Valve Assembly = <b>-09</b> Reverse Flow Output = <b>-15</b> Tamper Evident Kit = <b>-32</b> Non-resettable Total = <b>-64</b> 12" Extension (200 Series Only) = <b>-72</b> Hinged Display Cover = <b>-126</b>
	<b>Hot Tap</b> 3" - 10" pipe = <b>EX159</b> 10" - 48" pipe = <b>EX259</b>				

\* Immersible to maximum of 3 ft (1m), up to 2 weeks • Roytronic is a registered trademark of Milton Roy Company.